

# .200" (5,08mm) Center Crimp Terminal Housing

## 50802H-N Series

## Crimp Terminal Housing

### Features/Dimensions

- 2-12 Circuits
- UL 94V-2 nylon 66
- Molded pull tab
- With locking ramp
- Molded in locking arm for terminal
- Mates with 50802W series headers
- Mates with 39604T series terminal

inches  
mm

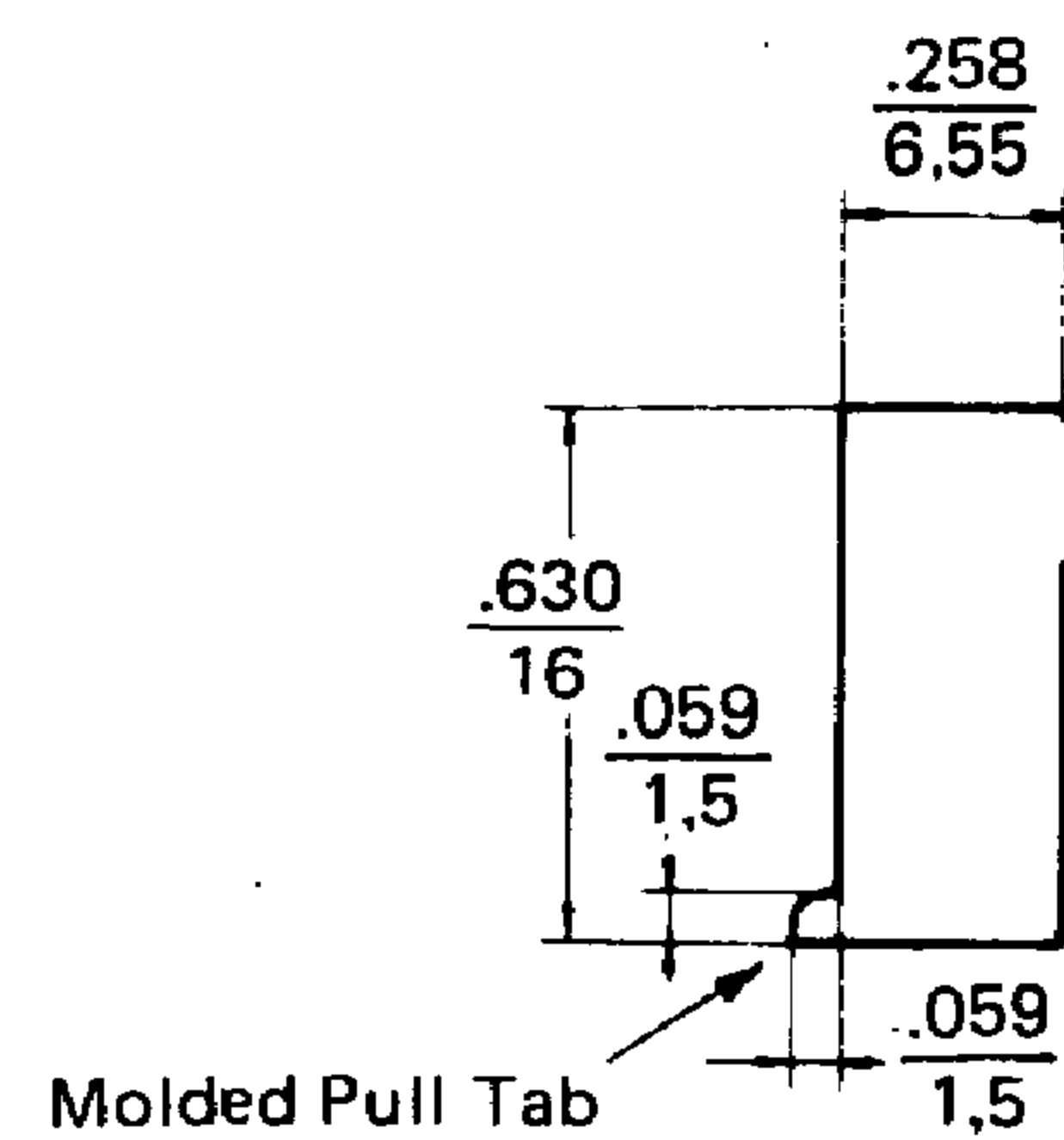
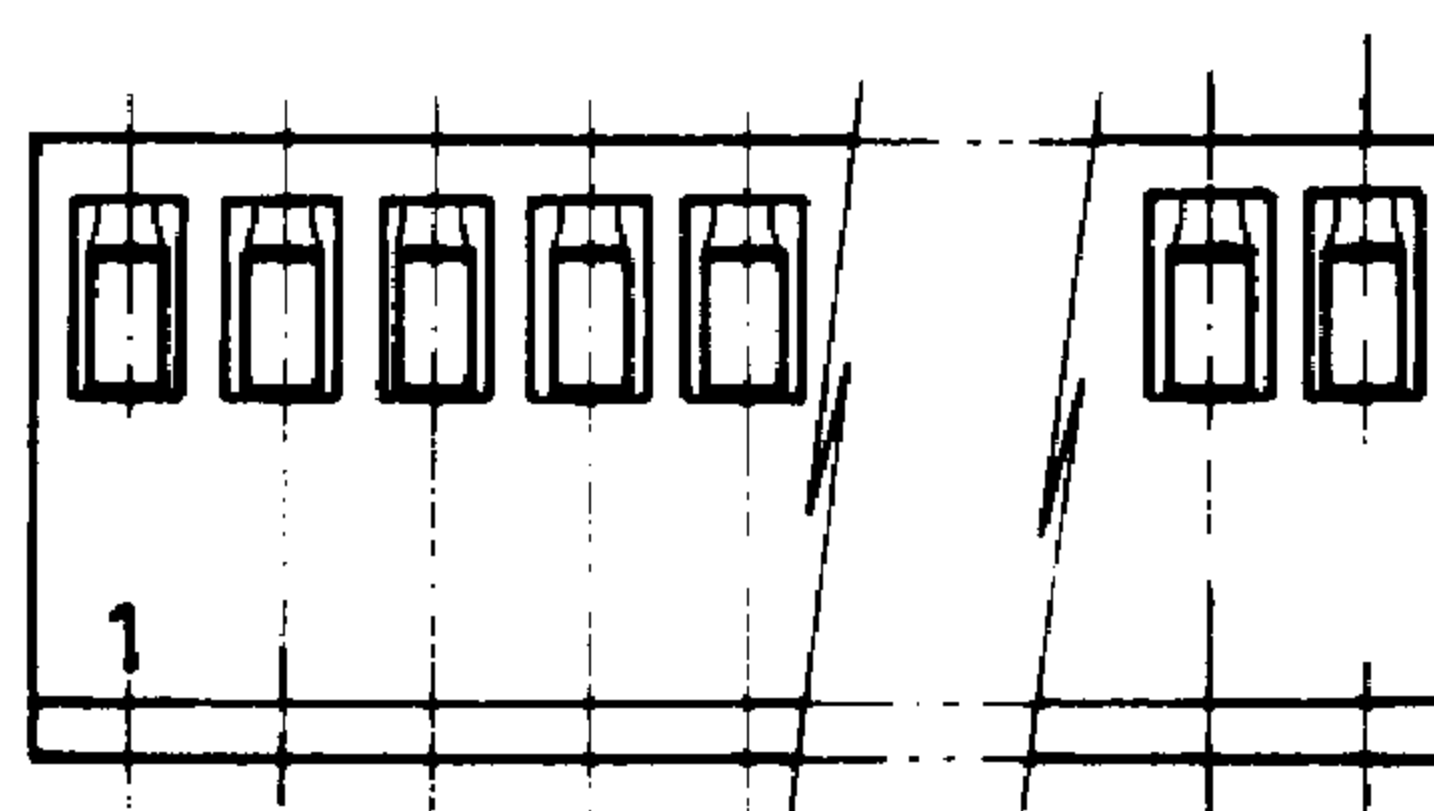
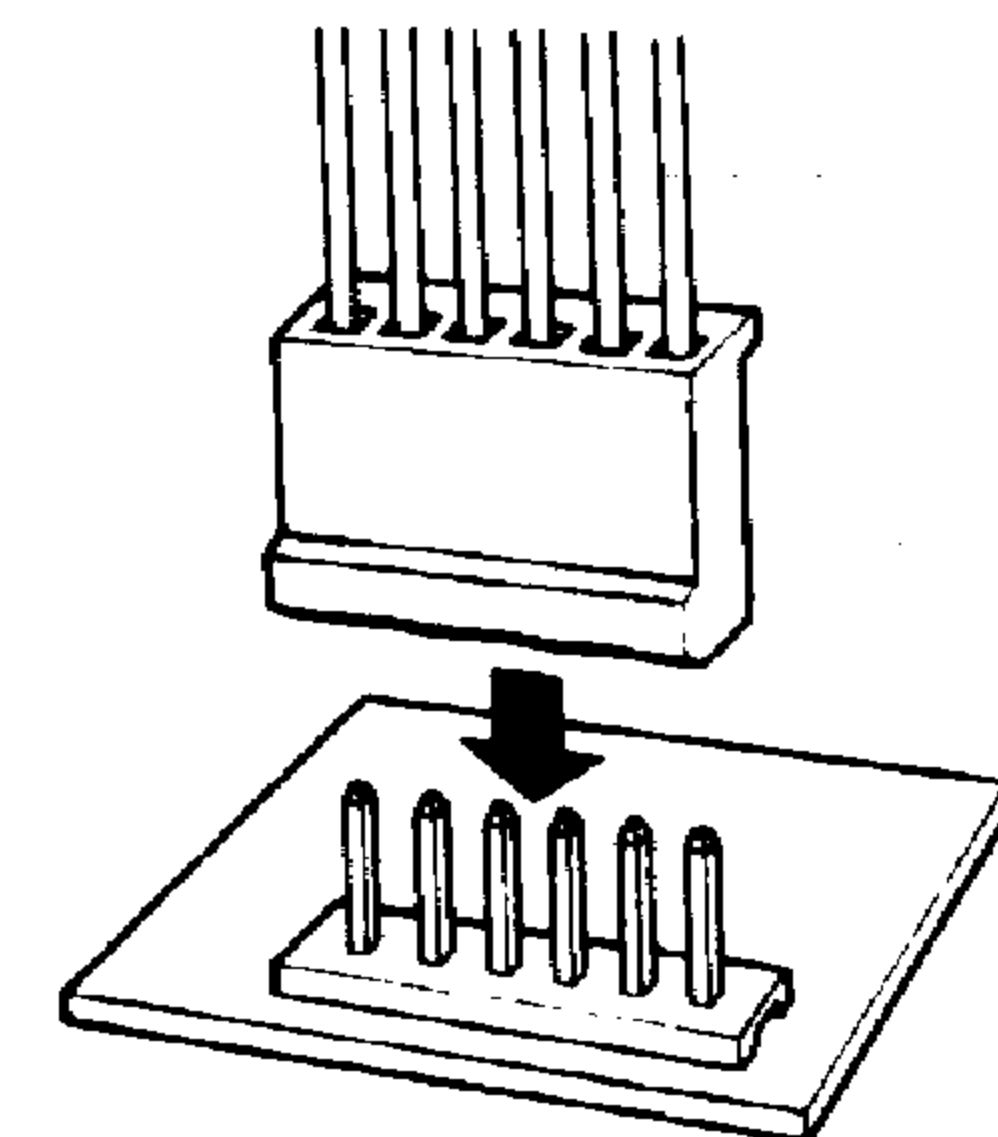
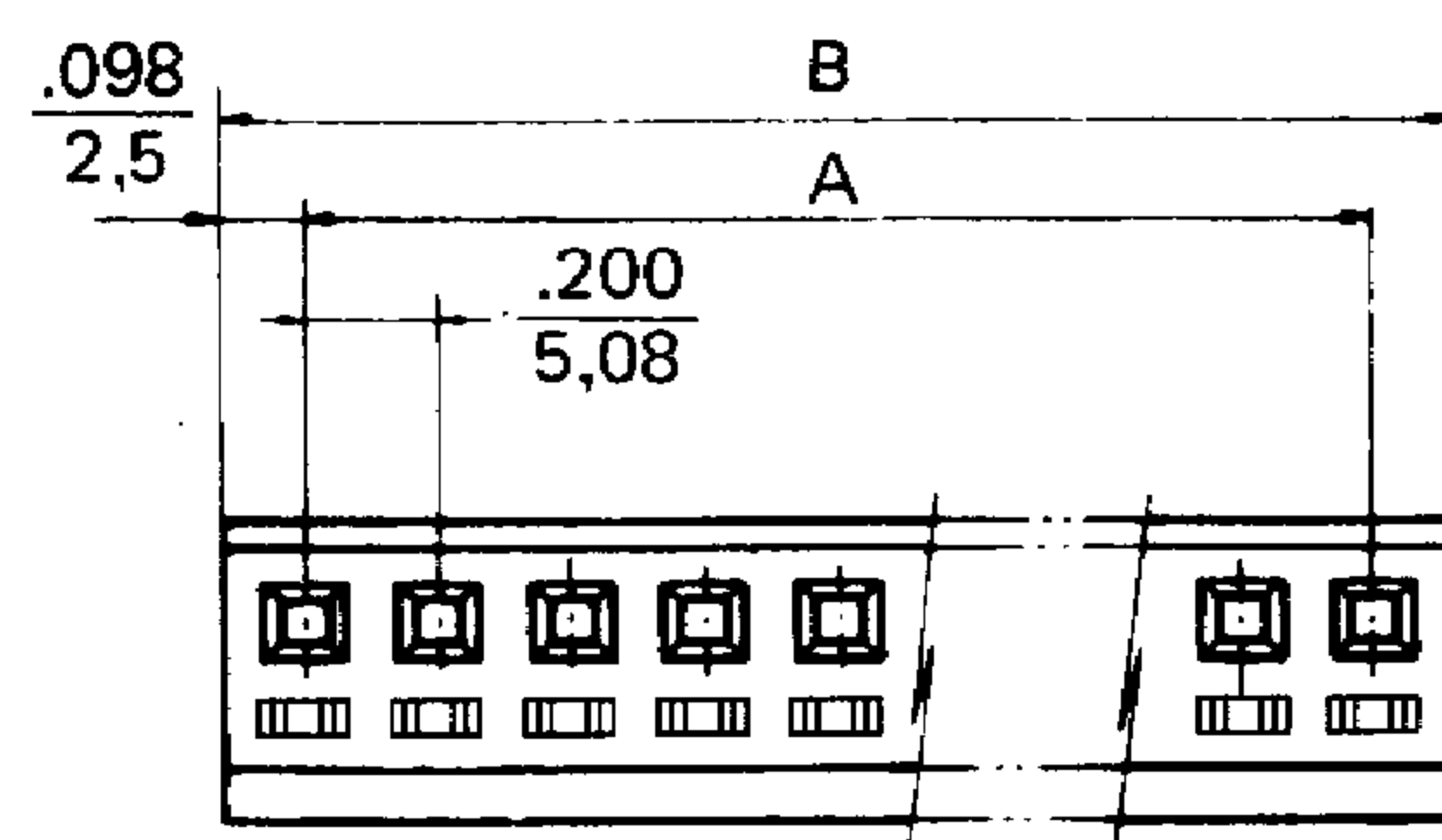

### Dimensional Information - in. (mm)

Circuits	Dim. A	Dim. B
2	.200 ( 5,08)	.407 (10,33)
3	.400 (10,16)	.607 (15,41)
4	.600 (15,24)	.807 (20,49)
5	.800 (20,32)	1.007 (25,57)
6	1.000 (25,40)	1.207 (30,65)
7	1.200 (30,48)	1.407 (35,73)

Circuits	Dim. A	Dim. B
8	1.400 (35,56)	1.607 (40,81)
9	1.600 (40,64)	1.807 (45,89)
10	1.800 (45,72)	2.007 (50,97)
11	2.000 (50,80)	2.207 (56,05)
12	2.200 (55,88)	2.407 (61,13)