

# .079"(2.0mm) Center Headers

## 20005WS-N Series Vertical Header

- 2 ~ 15 circuits available
- .024"(0.6mm) straight round pins
- Contact: Tin-plated brass
- Insulation: Nylon 66, UL 94V-0
- Mates with 20005H-N series housing

2 circuits

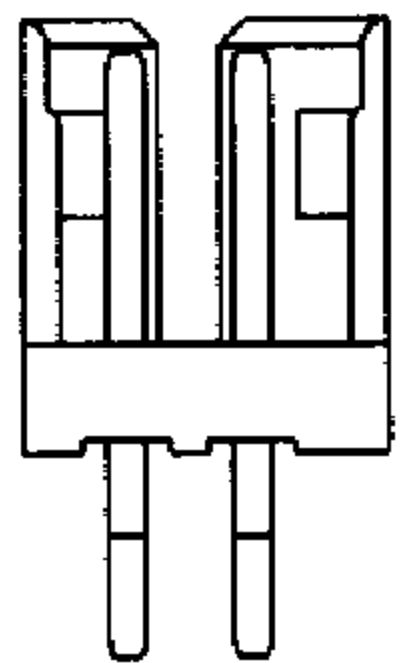

3 circuits

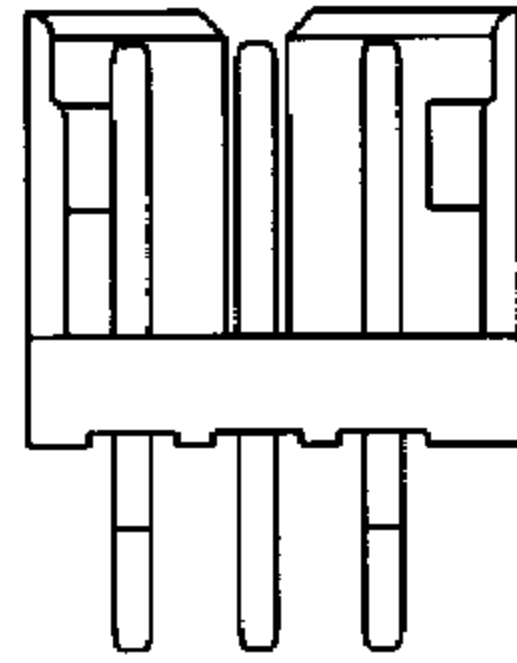

4 ~ 15 circuits

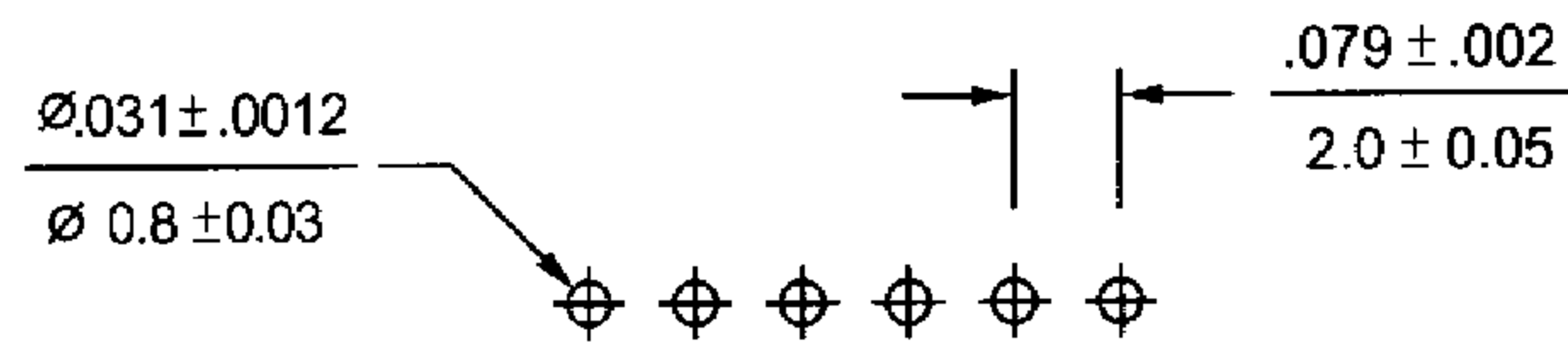
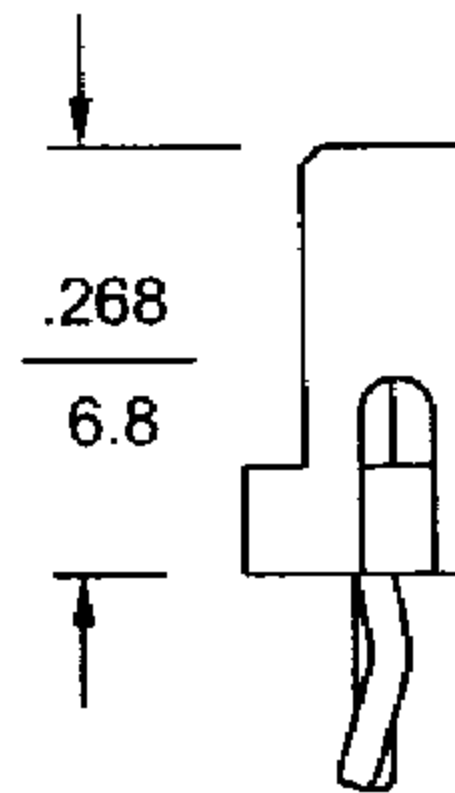
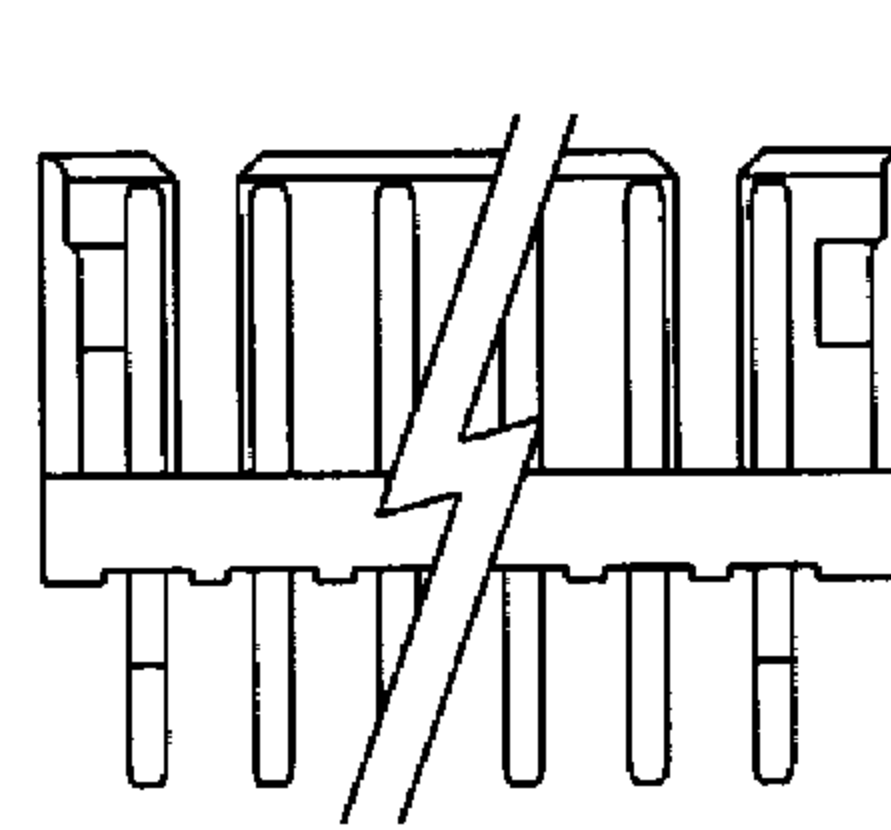
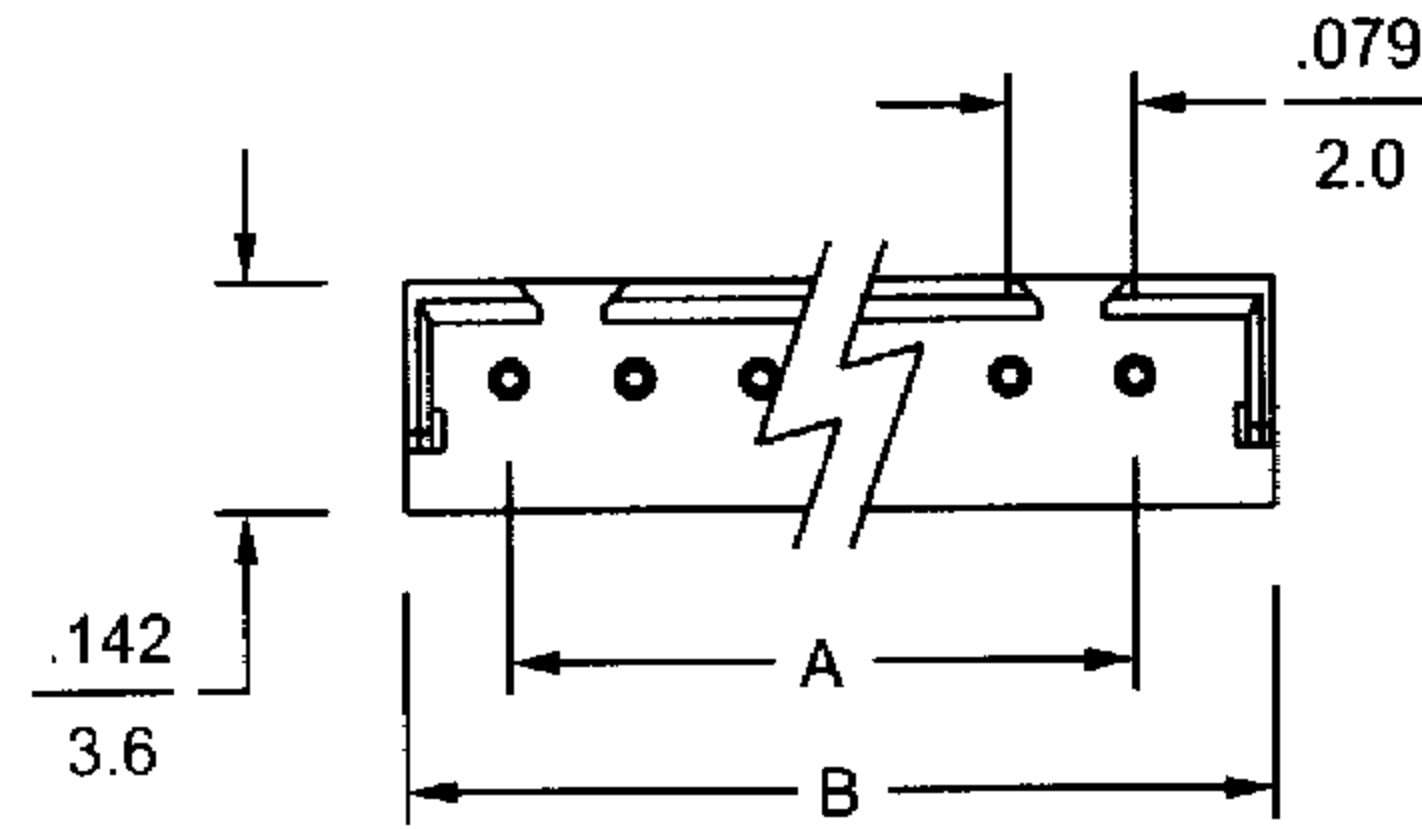

P.C.B. hole dimensions

inches  
mm

## 20005WR-N Series Right Angle Header

- 2 ~ 15 circuits available
- .024"(0.6mm) straight round pins
- Contact: Tin-plated brass
- Insulation: Nylon 66, UL 94V-0
- Mates with 20005H-N series housing

2 circuits

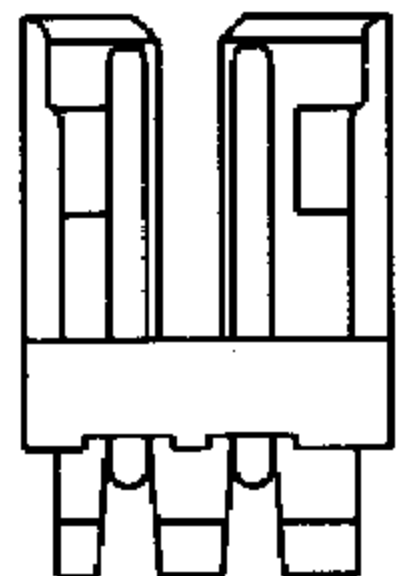

3 circuits

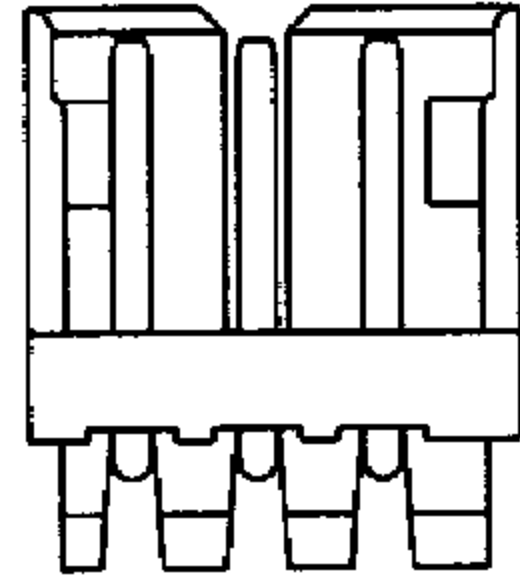

4 ~ 15 circuits

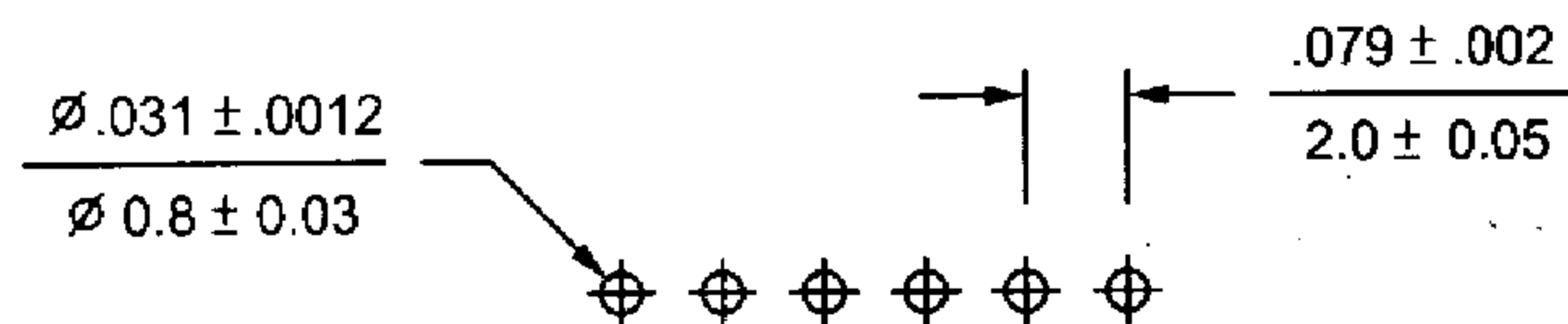
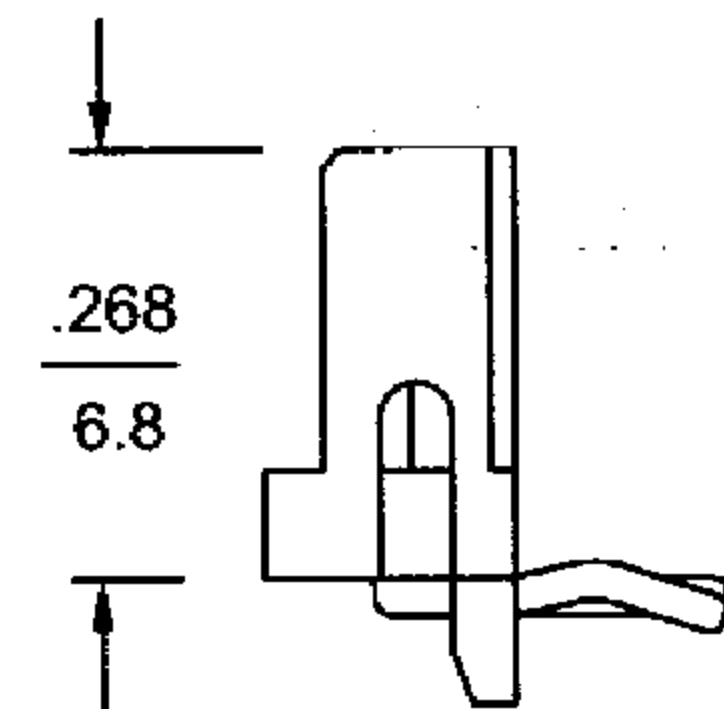
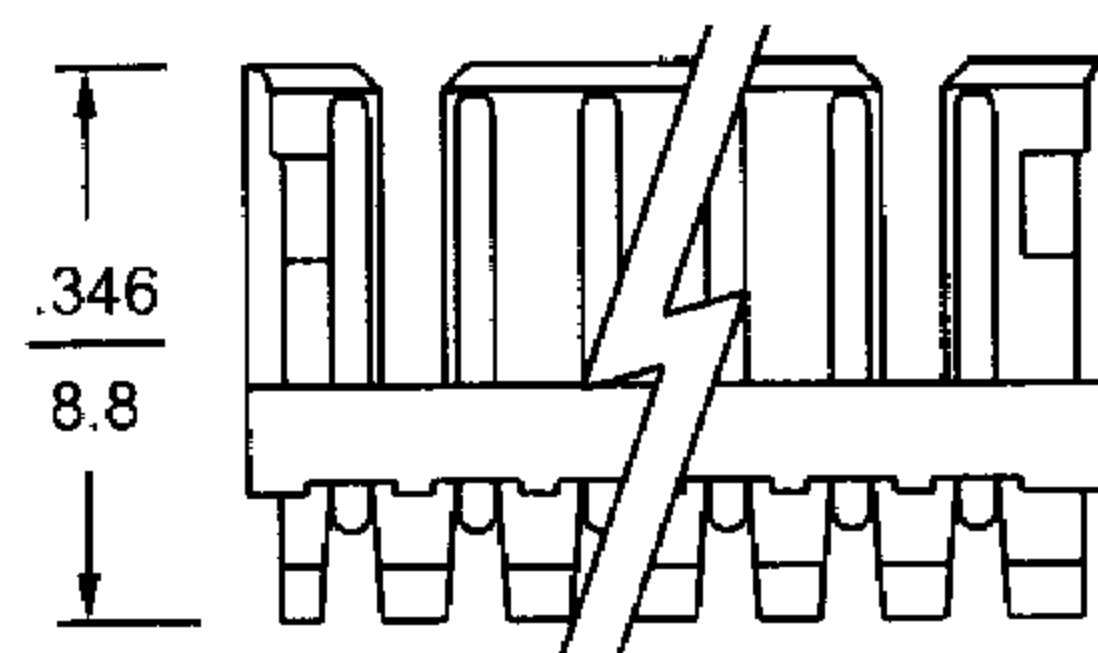
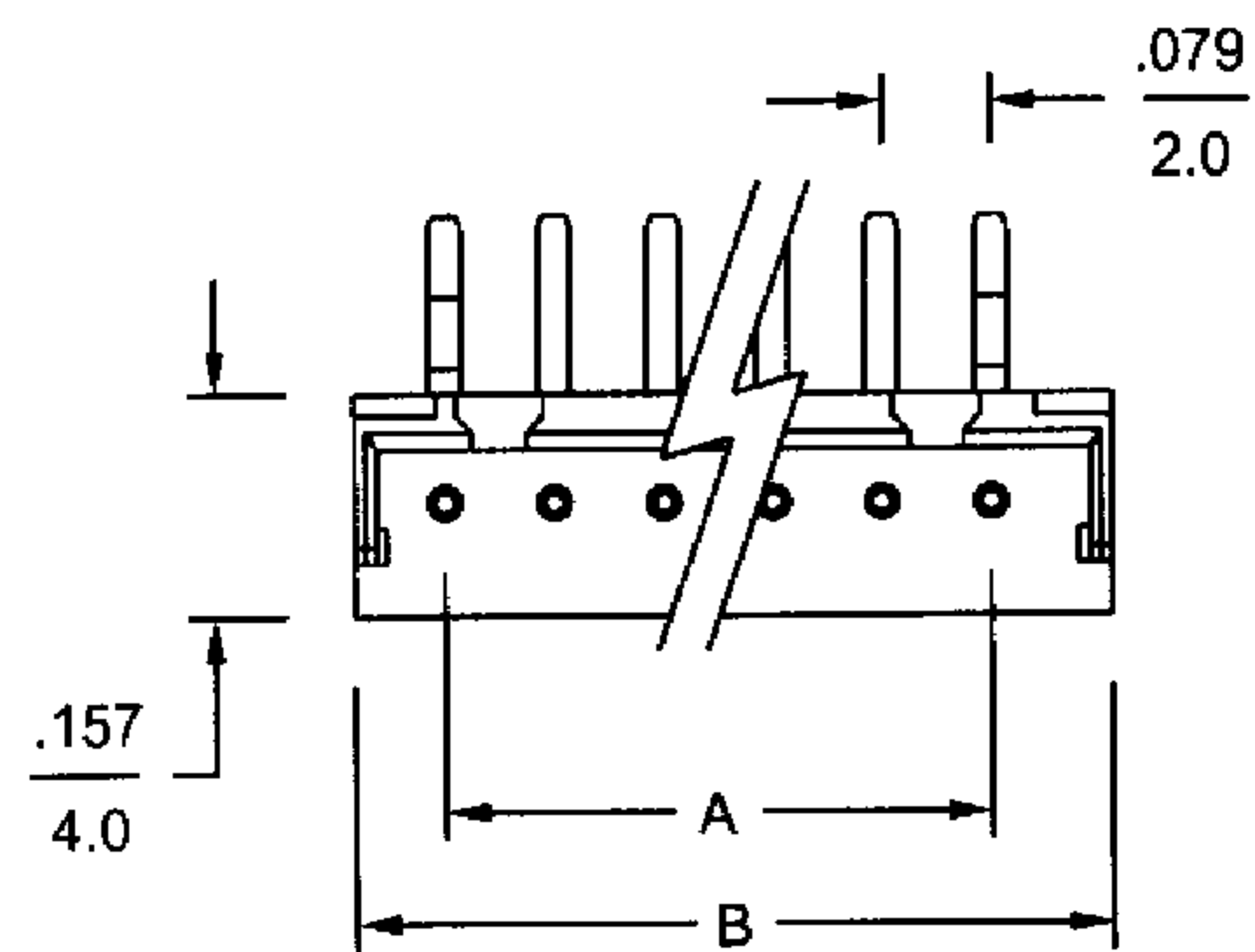

P.C.B. hole dimensions

inches  
mm

### Dimensional Information - in ( mm )

Circuits	Dim. A	Dim. B	Circuits	Dim. A	Dim. B	Circuits	Dim. A	Dim. B
2	0.079 ( 2.0)	0.230 ( 5.85)	7	0.472 (12.0)	0.624 (15.85)	12	0.866 (22.0)	1.018 (25.85)
3	0.157 ( 4.0)	0.309 ( 7.85)	8	0.551 (14.0)	0.703 (17.85)	13	0.945 (24.0)	1.096 (27.85)
4	0.236 ( 6.0)	0.388 ( 9.85)	9	0.630 (16.0)	0.781 (19.85)	14	1.024 (26.0)	1.175 (29.85)
5	0.315 ( 8.0)	0.467 (11.85)	10	0.709 (18.0)	0.860 (21.85)	15	1.102 (28.0)	1.254 (31.85)
6	0.394 (10.0)	0.545 (13.85)	11	0.787 (20.0)	0.939 (23.85)			